

**Female Elbows**

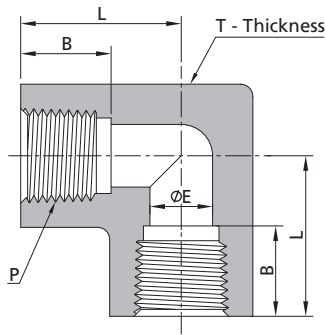

Female NPT Threads						
P-NPT Size, in.	Ordering Number	Dimensions, in. (mm)				Working Pressure psig (bar)
		L	B	E	T	
1/8	SS-HPE-FNS2	0.75 (19.1)	0.41 (10.4)	0.31 (8.0)	0.63 (15.9)	15000 (1034)
1/4	SS-HPE-FNS4	1.00 (25.4)	0.59 (15.0)	0.41 (10.4)	0.75 (19.1)	15000 (1034)
3/8	SS-HPE-FNS6	1.20 (30.6)	0.59 (15.0)	0.54 (13.8)	1.00 (25.4)	15000 (1034)
1/2	SS-HPE-FNS8	1.50 (38.1)	0.78 (19.8)	0.67 (17.0)	1.37 (34.9)	15000 (1034)
3/4	SS-HPE-FNS12	1.50 (38.1)	0.81 (20.6)	0.88 (22.3)	1.50 (38.1)	10000 (690)
1	SS-HPE-FNS16	1.91 (48.5)	1.00 (25.4)	1.11 (28.1)	1.75 (44.5)	10000 (690)

Female ISO Tapered Threads						
P-ISO Thread Size, in.	Ordering Number	Dimensions, in. (mm)				Working Pressure psig (bar)
		L	B	E	T	
1/8	SS-HPE-FRT2	0.75 (19.1)	0.41 (10.4)	0.31 (8.0)	0.63 (15.9)	15000 (1034)
1/4	SS-HPE-FRT4	1.00 (25.4)	0.59 (15.0)	0.41 (10.4)	0.75 (19.1)	15000 (1034)
3/8	SS-HPE-FRT6	1.20 (30.6)	0.59 (15.0)	0.54 (13.8)	1.00 (25.4)	15000 (1034)
1/2	SS-HPE-FRT8	1.50 (38.1)	0.78 (19.8)	0.69 (17.4)	1.37 (34.9)	15000 (1034)
3/4	SS-HPE-FRT12	1.50 (38.1)	0.81 (20.6)	0.90 (22.8)	1.50 (38.1)	10000 (690)
1	SS-HPE-FRT16	1.91 (48.5)	1.00 (25.4)	1.13 (28.7)	1.75 (44.5)	10000 (690)

**Male Tees**

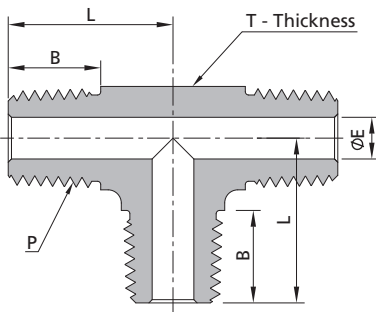

Male NPT Threads						
P-NPT Size, in.	Ordering Number	Dimensions, in. (mm)				Working Pressure psig (bar)
		L	B	E	T	
1/8	SS-HPT-NS2	0.75 (19.1)	0.38 (9.7)	0.19 (4.8)	0.50 (12.7)	15000 (1034)
1/4	SS-HPT-NS4	1.00 (25.4)	0.56 (14.2)	0.25 (6.4)	0.63 (15.9)	15000 (1034)
3/8	SS-HPT-NS6	1.10 (28.0)	0.56 (14.2)	0.31 (7.9)	0.75 (19.1)	15000 (1034)
1/2	SS-HPT-NS8	1.44 (36.6)	0.75 (19.1)	0.38 (9.6)	1.00 (25.4)	15000 (1034)
3/4	SS-HPT-NS12	1.56 (39.6)	0.75 (19.1)	0.58 (14.8)	1.37 (34.9)	10000 (690)
1	SS-HPT-NS16	1.89 (48.0)	0.94 (23.9)	0.79 (20.0)	1.50 (38.1)	10000 (690)

Male ISO Tapered Threads						
P-ISO Thread Size, in.	Ordering Number	Dimensions, in. (mm)				Working Pressure psig (bar)
		L	B	E	T	
1/8	SS-HPT-RT2	0.75 (19.1)	0.38 (9.7)	0.19 (4.8)	0.50 (12.7)	15000 (1034)
1/4	SS-HPT-RT4	1.00 (25.4)	0.56 (14.2)	0.25 (6.4)	0.63 (15.9)	15000 (1034)
3/8	SS-HPT-RT6	1.10 (28.0)	0.56 (14.2)	0.31 (7.9)	0.75 (19.1)	15000 (1034)
1/2	SS-HPT-RT8	1.44 (36.6)	0.75 (19.1)	0.38 (9.6)	1.00 (25.4)	15000 (1034)
3/4	SS-HPT-RT12	1.56 (39.6)	0.75 (19.1)	0.58 (14.8)	1.37 (34.9)	10000 (690)
1	SS-HPT-RT16	1.89 (48.0)	0.94 (23.9)	0.79 (20.0)	1.50 (38.1)	10000 (690)

Fittings  
Tubing  
Quick Couplings  
Line Filters  
Valves  
Sour Service Products  
Subsea Valves  
Tools and Installation Instructions  
Technical Information  
Part Number Crossover Charts